

# LP-Based Heuristic Procedure for the Optimal Design of Water Using Networks with Multi-contaminants

João Teles<sup>1</sup>, Pedro Castro<sup>1</sup>, Ana Barbosa-Póvoa<sup>2</sup> and Augusto Novais<sup>1</sup>

<sup>1</sup>DMS/INETI, 1649-038 Lisboa, Portugal

<sup>2</sup>CEG/IST, 1049-001 Lisboa, Portugal

## Abstract

This paper proposes a new strategy for the optimal design of water-using networks in industrial systems featuring possibly more than a single water source and multiple contaminants. The model formulation is supported on a superstructure that exploits reuse opportunities and gives rise to a non-convex nonlinear problem which often leads to local optimal solutions. To overcome this, the new approach generates multiple initialization points, one for each possible sequence of operations, where a particular starting point is obtained by the sequential solution of a small set of related linear programs. The best solution of the several nonlinear problems that are solved is then assumed to be the global optimal solution. The results obtained for a set of case studies have shown that the best initialization point is often the global optimal solution and that the procedure as a whole is efficient in escaping local optima.

## 1. Introduction

Water is a key element for the normal functioning of industrial processes, especially in the chemical and petrochemical industry where it is intensively used for many different purposes: as a reactant, heating or cooling utility and as a cleaning agent for equipment. But because water is a scarce resource and one of industry's major waste products reducing waste water has become one of the greatest challenges facing the process industries. This is even further justified by the fact that fresh water is expensive and that stricter discharge regulations have caused the price of waste water treatment facilities to rise significantly in the last decades. As a consequence, several contributions have appeared in the literature that looked into the targeting/design problem of the water-using network of a plant.

A method for the problem of targeting water-using networks, which is referred to as the Water Allocation Planning (WAP) problem, was firstly introduced by Wang & Smith (1994). It consists of a graphical approach that introduces the important concepts of "water pinch" and "limiting water profile" and gives, as a result, the minimum freshwater requirement of the entire process in a direct way. Although the authors addressed both single contaminant and multi-contaminant problems, their targeting design method is only efficient for the former since their algorithm often fails to identify the optimal solutions for multi-contaminant systems.

While water-using networks of plants involving just a few operations are fairly simple and water savings at or near the optimum can be achieved, for a large number of

operations the piping network becomes very complicated and hard to design. For this latter class of WAPs, all methodological elements do not suffice to prevent the use of complicating terms and variables in the associated mathematical models and due to the presence of bilinear terms in some of the model constraints, a non-linear programming problem (NLP) inevitably results (Doyle & Smith, 1997). As the NLPs are non-convex, local optimization solvers can miss global optimum solutions and therefore efficient ways of initializing model variables and of avoiding local optimal solutions are required.

This paper presents an alternative initialization method to the one given by Doyle and Smith, 1997. It is also a linear programming (LP) based procedure which, instead of fixing the maximum outlet concentration variables to their predefined upper bounds, assumes a fixed sequence of operations and solves several partial problems sequentially. Since while tackling a particular operation, the outlet concentrations from all its predecessors in the sequence are known, no bilinear terms appear. The approach is then applied for all possible sequences of operations and the resulting solutions are used as starting points for the general NLP. The best solution from the set of NLPs solved is then assumed to be the global optimal solution. Since there is no theoretical guarantee that the proposed approach can achieve global optimal solutions, this can be viewed as a heuristic procedure or a systematic search methodology for targeting very good solutions. A case study is shown to illustrate some attributes of the proposed approach while providing at the same time a comparison to the initialization procedure by Doyle and Smith, 1997.

## 2. Problem statement

The design of a water system involves a set  $W$  of fresh water sources containing a number of pollutants (set  $C$ ), with known concentrations ( $c_{w,c}^{wat}$ ), that are available to satisfy the demands of every water-using operation (set  $O$ ), both in terms of mass to be transferred ( $\Delta m_{i,c}$ ,  $i \in O$ ) and inlet ( $c_{i,c}^{in\ max}$ ) and outlet ( $c_{i,c}^{out\ max}$ ) maximum concentration levels, for all relevant contaminants. The goal is to find the network configuration that will minimize the overall demand for fresh water, and thus minimize waste water generation.

## 3. General NLP formulation

With the purpose of conducting a systematic search to determine globally optimal designs, a general network superstructure, similar to the one proposed by Wang & Smith (1994), was utilized as the basis for the NLP model formulation (see figure 1). It includes the full set of fresh water streams and operation units, as well as several nodes that are either stream splitters, located at the inlet ( $SP_b$ ) of the system and at the outlet ( $SP_a$ ) of the operation units, or mixers at the inlet ( $MX_b$ ), of the operation units. A comprehensive connectivity between the several nodes, embeds all possible alternative arrangements, including stream reuse and recycling as well as the effluent streams to the wastewater treatment system located downstream, which is not handled here.

The mathematical model of the problem uses the following variables:  $F_{w,i}^{wat}$ , is the flow rate of fresh water source  $w$  needed to satisfy operation unit  $i$ ;  $C_{i,c}^{in}$  and  $C_{i,c}^{out}$  are respectively the operations maximum inlet and outlet concentrations,  $F_i^{tot}$ , is the total flowrate into operation  $i$ ;  $F_{j,i}^{oper}$ , is the total flowrate from operation  $j$  to operation  $i$ ; and  $F_i^{tsys}$  represents the outlet flow rate from operation  $i$  heading for the treatment system.

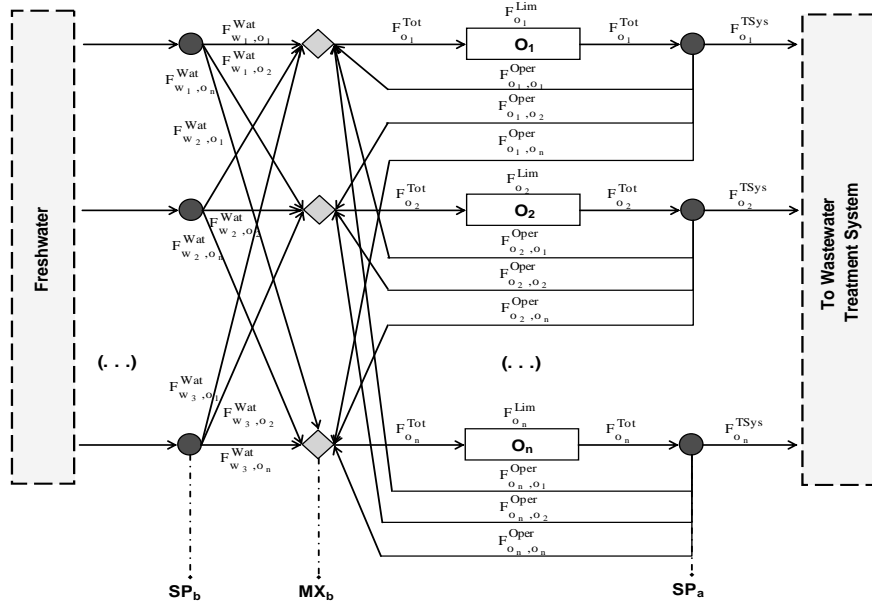

Figure 1. General superstructure for the design of water-using networks

The model is presented next. Eq 1 is the objective function where the minimization of the total freshwater flow rate into the system is defined. Eq 2 is the total flow balance over the mixers  $MX_b$ , where the inlet flow to operation  $i$  may come from the freshwater streams and/or from the units' outlet streams. Eq 3 is the total flow balance over the splitters  $SP_a$ , where the outlet flow may be heading to the same or other water-using units and/or to the treatment system. Eq 4 is the mass balance over the mixers  $MX_b$  and is written for all contaminants. Eq 5 is the mass balance over the operation units. Finally, Eq 6 represents the upper bounds on the operations inlet and outlet concentrations.

$$\text{Min} \sum_{w \in W} \sum_{i \in O} F_{w,i}^{wat} \quad (1)$$

$$F_i^{tot} = \sum_{w \in W} F_{w,i}^{wat} + \sum_{j \in O} F_{j,i}^{oper}, \forall i \in O \quad (2)$$

$$F_i^{tot} = F_i^{tsys} + \sum_{j \in O} F_{i,j}^{oper}, \forall i \in O \quad (3)$$

$$F_i^{\text{tot}} \cdot C_{i,c}^{\text{in}} = \sum_{w \in W} F_{w,i}^{\text{wat}} \cdot c_{w,c}^{\text{wat}} + \sum_{j \in O} F_{j,i}^{\text{oper}} \cdot C_{j,c}^{\text{out}}, \forall i \in O, \forall c \in C \quad (4)$$

$$\Delta m_{i,c} = \sum_{j \in O} F_{j,i}^{\text{oper}} \cdot (C_{i,c}^{\text{out}} - C_{j,c}^{\text{out}}) + \sum_{w \in W} F_{w,i}^{\text{wat}} \cdot (C_{i,c}^{\text{out}} - c_{w,c}^{\text{wat}}), \forall i \in O, \forall c \in C \quad (5)$$

$$C_{i,c}^{\text{in}} \leq c_{i,c}^{\text{in max}}, C_{i,c}^{\text{out}} \leq c_{i,c}^{\text{out max}}, \forall i \in O, \forall c \in C \quad (6)$$

#### 4. Overview of initialization method of Doyle & Smith (1997)

The non-linear problem stated above features non linear constraints containing bilinear terms resulting from the product of two continuous variables, flows and concentrations in Eq 4 and Eq 5. Such bilinear terms impose significant difficulties for the commercial NLP solvers. In order to initialize the variables and to obtain a good starting upper bound, Doyle & Smith assumed that the outlet concentrations of all contaminants are equal to their predefined maximum values. Feasibility is ensured by relaxing eqs 4-5 to its linear counterparts, eq 7-8.

$$F_i^{\text{tot}} \cdot c_{i,c}^{\text{in max}} \geq \sum_{w \in W} F_{w,i}^{\text{wat}} \cdot c_{w,c}^{\text{wat}} + \sum_{j \in O} F_{j,i}^{\text{oper}} \cdot c_{j,c}^{\text{out max}}, \forall i \in O, \forall c \in C \quad (7)$$

$$\Delta m_{i,c} \leq \sum_{j \in O} F_{j,i}^{\text{oper}} \cdot (c_{i,c}^{\text{out max}} - c_{j,c}^{\text{out max}}) + \sum_{w \in W} F_{w,i}^{\text{wat}} \cdot (c_{i,c}^{\text{out max}} - c_{w,c}^{\text{wat}}), \forall i \in O, \forall c \in C \quad (8)$$

This LP formulation provides a reasonable starting point for the original NLP, however, there is always the possibility for the NLP solver to be trapped in local optima. In order to overcome this difficulty we present an alternative initialization strategy.

#### 5. Novel initialization strategy

Although, there is no theoretical guarantee that the new proposed approach can yield global optima, it can be viewed as a feasible heuristic procedure to avoid the mentioned hindrance. The procedure can be described as follows.

Multiple substructures of the complete superstructure based on different water reuse sequences (operation units in series) are defined. For a given serial sequence of units, the total freshwater minimization problem (NLP) is further split into  $|O|$  subproblems (LPs), which are solved sequentially starting from the first to the last operation in the sequence. For the active operation, the problem of minimizing its freshwater input is a LP since its possible inlet streams are, besides freshwater, the outlet streams from all previous (in the sequence) operations for which both the available (not already allocated to other operations) flowrate and concentration have previously been determined. Thus, the bilinear terms are automatically avoided. Overall, the proposed strategy involves the solution of  $|O| \cdot |O|!$  LPs followed by  $|O|!$  general NLPs (in contrast to the LPs they are no longer constrained to a given sequence of units), but since these are solved almost instantaneously, larger problems can also be solved quite easily. The best solution of all NLPs is then assumed to be the global optimal solution.

The LP formulation corresponding to unit  $i$  and sequence  $s$ , is given next. Eq 9 is the objective function. Eq 10 states that the flowrate from unit  $j \in \mathcal{R}_i^s$  (set of all operation units for which the position in sequence  $s$  precedes the one of unit  $i$ ) must not exceed

the flowrate into unit  $j$  minus that already allocated to other units. Eqs 11-12 ensure that the inlet and outlet maximum concentrations are not exceeded (equivalent to eq 6). Note that the parameters  $f_{j,q}^{oper}$  and  $c_{j,c}^{out}$  are known results from previous iterations.

$$\text{Min } \sum_{w \in W} F_{w,i}^{wat}, \forall i \in O \quad (9)$$

$$F_{j,i}^{oper} \leq \sum_{w \in W} f_{w,j}^{wat} + \sum_{u \in \mathcal{R}_j^s} f_{u,j}^{oper} - \sum_{q \in \mathcal{R}_i^s, j \in \mathcal{R}_q^s} f_{j,q}^{oper}, \forall i \in O, \forall j \in \mathcal{R}_i^s \quad (10)$$

$$\sum_{w \in W} F_{w,i}^{wat} \cdot c_{w,c}^{wat} + \sum_{j \in \mathcal{R}_i^s} F_{j,i}^{oper} \cdot c_{j,c}^{out} \leq \left( \sum_{w \in W} F_{w,i}^{wat} + \sum_{j \in \mathcal{R}_i^s} F_{j,i}^{oper} \right) \cdot c_{i,c}^{in \max}, \forall i \in O, \forall c \in C \quad (11)$$

$$\sum_{w \in W} F_{w,i}^{wat} \cdot c_{w,c}^{wat} + \sum_{j \in \mathcal{R}_i^s} F_{j,i}^{oper} \cdot c_{j,c}^{out} + \Delta m_{i,c} \leq \left( \sum_{w \in W} F_{w,i}^{wat} + \sum_{j \in \mathcal{R}_i^s} F_{j,i}^{oper} \right) \cdot c_{i,c}^{out \max}, \forall i \in O, \forall c \in C \quad (12)$$

## 6. Example problem

A particular example is used to illustrate the capabilities of the new method in comparison with that proposed previously by Doyle & Smith (1997). The problem features 3 fresh water streams, 6 contaminants and 5 operation units, and the data is given in table 1. The mathematical models and solution strategies were implemented in GAMS and solved on a Pentium-4 3.0 GHz machine, using the CONOPT solver for the NLPs. The total computational effort (total of 720 problems, i.e.,  $5 \cdot 5! = 600$  LPs plus 120 NLPs) was approximately 152 CPUs.

The best solution found is characterized by a total freshwater consumption of 280.771 t/h and uses all three postulated water sources (see figure 2). The optimal solution can be found for many sequences (see figure 3 – our method and Doyle and Smith method (DS)) with the most interesting result being that the proposed initialization procedure, besides generating feasible networks, could also find the optimal solution. Although, other examples (not presented here) have shown that this is not always true, this work presents a way of replacing the solution of a NLP by the solution of a series of LPs. On the other hand, the initialization procedure of Doyle & Smith (1997) leads, in the present example, to an infeasible water-using network corresponding to a starting point of 316.054 t/h and, after solving the NLP, to a suboptimal solution of 283.977 t/h.

## 7. Conclusions

This paper presents a new LP-based initialization strategy for the optimal design of water-using networks with multi-contaminants, which is formulated as a NLP. It generates multiple starting points, one for each possible sequence of operations, and assumes that the best solution found from the general NLPs is the global optimal solution. Through the solution of an example problem it was shown that the new strategy can find better solutions than the method of Doyle & Smith (1997) and that for the best operation sequence(s), the solution of the NLP can be replaced by that of a series of LPs.

**References**

Doyle, S.; Smith, R., 1997, Trans IChemE, 75, Part B, 181.

Wang, Y., Smith, R., 1994, Chem. Eng. Sci.,49, 981.

Table 1. Problem data for example problem.

Operation Unit	Limiting Water Flow Rate (t/h)	Contaminants Concentrations (ppm)												Water Sources			
		a		b		c		d		e		f		Contaminant Conc. (ppm)	a	b	3
		C <sub>In</sub> Max	C <sub>Out</sub> Max	C <sub>In</sub> Max	C <sub>Out</sub> Max	C <sub>In</sub> Max	C <sub>Out</sub> Max	C <sub>In</sub> Max	C <sub>Out</sub> Max	C <sub>In</sub> Max	C <sub>Out</sub> Max	C <sub>In</sub> Max	C <sub>Out</sub> Max				
1	64	45	139	52	400	189	435	33	37	210	378	24	124	4	4	0	
2	34	120	245	30	125	30	85	12234	14728	98	124	656	754	5	6	6	
3	126	142	222	420	459	200	567	13	56	637	768	24	58	0	2	4	
4	28	20	47	25	367	15	320	25	433	454	589	256	467	8	7	5	
5	120	350	850	48	3560	260	400	21	56	278	436	12	90	0	2	2	

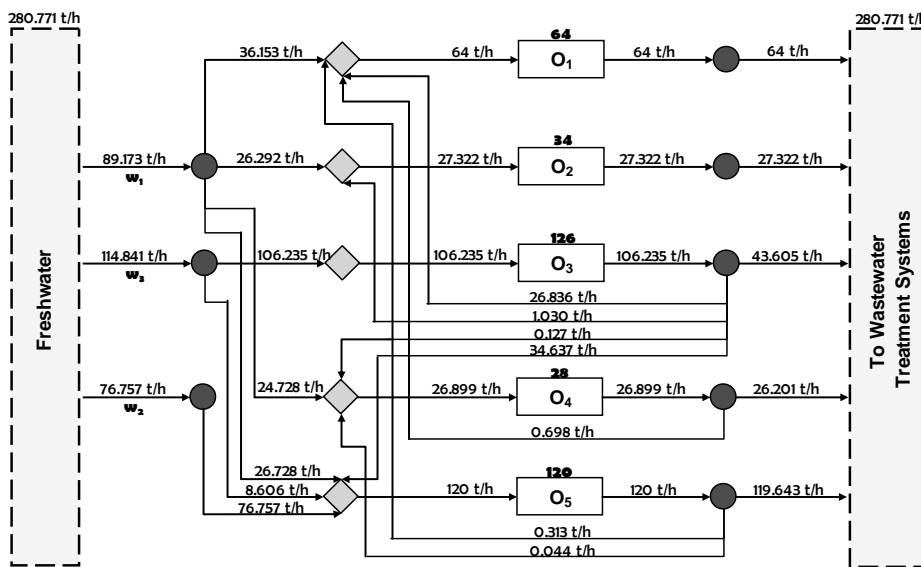

Figure 2. Optimal water using network for example problem.

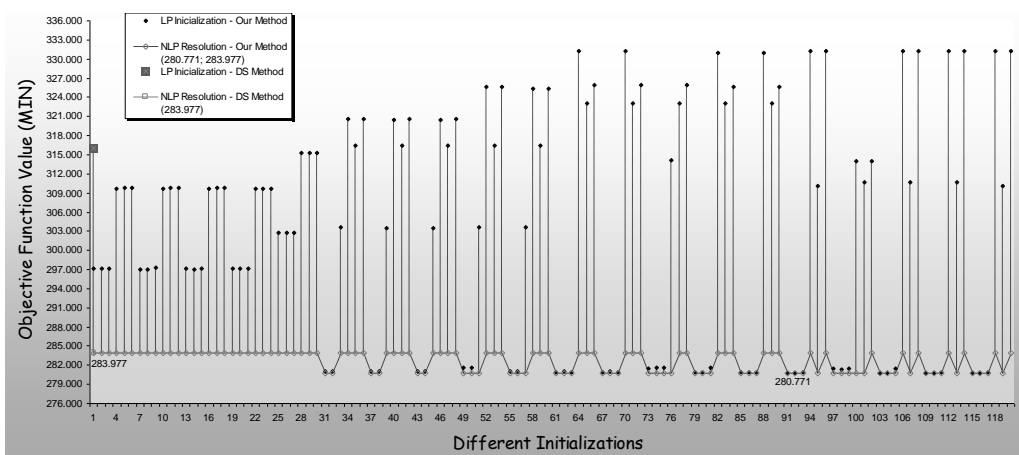

Figure 3. Objective function values corresponding to initializations and final solutions.