

LEAD BIOREMOVAL BY CORK RESIDUES AS BIOSORBENT

Dora Mota¹, Paula Marques¹, Carlos Pereira², Luís Gil² and Maria Fernanda Rosa¹

1. I.N.E.T.I.- Unit of Biomass / Department of Renewable Energy, Estrada do Paço do Lumiar, 1649-038 Lisboa, Portugal. Telephone: 351.1.7162712 Fax: 351.1.7163797 Email: paula.marques@ineti.pt
2. I.N.E.T.I.- Unit of Cork Technology / Department of Chemical Industries Technology, Estrada do Paço do Lumiar, 1649-038 Lisboa, Portugal.

SUMMARY

The goal of this work was to study the bioremoval process of Pb(II) ions from aqueous dilute solutions by cork granulates (1-2 mm) from a Portuguese cork processing company. The effect of physical-chemical parameters, such as initial pH metal solution, initial metal and biosorbent concentrations and cork pre-treatments on the metal removal efficiency were investigated.

The results showed that the optimum initial pH for Pb(II) removal was in the range 3-3.5, leading to removal yields of about 90-100% for initial metal concentrations of 10-100 mg/L. Cork granulates without treatment provided a higher removal yield (93%) than the biomass submitted to previous extraction with deionised water (80%), ethyl acetate (83%) and ethanol (88 %). The Langmuir model showed a very good correlation with experimental results ($r^2=0.995$) and the Q_{max} was determined as being 5.3 mg Pb(II)/g cork.

The optimisation of a continuous processes for Pb(II) (10 mg/L) bioremoval was performed using the factorial design methodology. On the best operating conditions, two tubular reactors running in sequential mode, in order to achieve a higher effluent volume with $[Pb(II)] \leq 1$ (MAV). Chemical characterization of the effluent before discharge in terms of COD, TOC and phenolic compounds showed values lower than the ones allowed by environmental legislation.

INTRODUCTION

The intensification of industrial activity during the last few years has greatly contributed to the increase of heavy metals in the environment, mainly in the aquatic systems. Heavy metals are dangerous contaminants that are accumulated by the living organisms and, up to now, there were no widely accepted methods to have them removed. Moreover, conventional technologies traditionally used for the removal of heavy metals from aqueous solutions are expensive and inefficient at low metal concentrations (Chubar *et al.*, 2004a).

Biosorption, which is a property of different types of biomass (biosorbents) to bind and concentrate heavy metals from even very dilute aqueous solutions, is one of the most promising technologies that can be used for this purpose (Göksungur *et al.*, 2005; Marques *et al.*, 2000). The ionic binding of metallic ions by biomass can be described by the following equation:



where M represents the metal, n its charge and B the biosorptive active centre. According to reaction (1), the pH can influence the metal ions biosorption because of the competition between the metal and H^+ ions for the active biosorption sites (Santos *et al.*, 2004; Chubar *et al.*, 2004a; Marques *et al.*, 2000).

The metal concentration removed by the biomass, Q (mg of metal/g of biomass), can be obtained using the following mass balance:

$$Q_e = \frac{(C_0 - C_e)V}{M} \quad (2)$$

were C_0 and C_e are, respectively, the initial and the equilibrium metal concentration in solution (mg dm^{-3}), Q_e is the amount of metal adsorbed per gram of the dried biomass at equilibrium (mg g^{-1}), V (dm^3) the total volume of the solution and M (g) the mass of dried biomass (Santos *et al.*, 2004).

In the last two decades, a growing research interest into the production of low-cost adsorbents for heavy metals removal has occurred (Marques *et al.*, 2000; Palma *et al.*, 2003; Chubar *et al.*, 2004a; Santos *et al.*, 2004; Garg *et al.*, 2004; Marques *et al.*, 2005; Sarin and Pant, 2006; Marques *et al.*, 2006; Singh *et al.*, 2006). These biomaterials present different types of functional groups, such as carboxylic, sulphate, phosphate and amino groups, which are the binding sites for the ion exchange and complexation reactions. They may be side-agricultural, forest and industrial products. The choice of the biomass should be based on its origin, type and chemical composition and on the composition of the solution to be treated. Moreover, sorption properties of an adsorbent, like its uptake capacity, can be improved/changed by several pre-treatments or modification techniques (Chubar *et al.*, 2004b).

Cork oak tree is very abundant in several Mediterranean countries due to the high production of cork stopped for the wine industry. Portugal has a leading position in the cork industry due to the quality and quantity of cork stopper produced, which amount to 50% of the total consumption by the World wine industry (Chubar *et al.*, 2004a; Gil L, 2006).

In the heavy metals bioremoval area, cork is a promising biosorbent because of its high content of fatty acids. In fact, chemically, cork is composed of five groups components (Gil L, 1998; Gil L Moiteiro, C, 2003): Suberin (a complex mixture of fatty acids and heavy organic alcohols; $\approx 45\%$ w/w), tannins ($\approx 6\%$ w/w), polysaccharides ($\approx 12\%$ w/w), lignin (polymer of partially aromatic structure and high molecular weight where monomer units are organic; $\approx 27\%$ w/w), alkanes and long chain alcohols. The mineral content, usually referred to as the cork ash level, is low ($\approx 5\%$). The most abundant element is calcium (0.038-0.625% w/w), followed by phosphorous, iron, magnesium and aluminium. Cork residues used as biosorbent in this work have a very low commercial value.

The objective of this work was to evaluate the adsorption capacity of Pb(II) from aqueous solutions by untreated and pre-treated cork granulates in both batch with total external recirculation and continuous modes. The optimisation of a continuous process for Pb(II) bioremoval, was carried out using a 2^2 factorial central composite design and results displayed by the response surface method.

MATERIALS AND METHODS

The cork granulates used as biosorbent were supplied by the Portuguese Company Granotec. In all experiments, particle cork size was 1-2 mm, as previously established (Dora, 2004; Marques *et al.* 2005). The chemicals used were analytical grade and were supplied by Merck.

Metal analyses were carried out by AAS (Pye Unicam série 8620), pH measurements were performed using a WTW pH meter (model 340-A) and chemical characterization in terms of total organic carbon (TOC) was carried out using a Shimadzu TOC analyser (model 5050-A). Chemical oxygen demand (COD) and phenols concentrations were evaluated using analytical

kits from Merck in the range 4.0-40.0 mgdm⁻³ and the colorimetric Föllin-Ciaucalteau method, respectively, advised by the Portuguese environmental legislation.

Metal Binding Experiments

Heavy metal sorption by original and pre-treated cork granulates was studied in batch with total external recirculation and in continuous experimental conditions. Tests were carried out in a tubular reactor at room temperature (Figures 1 and 2). Stock solution of 1000 mgdm⁻³ of Pb(II) solutions was prepared by dissolving Pb(NO₃)₂ (p.a., Merck, Germany) in deionised water, at room temperature. The resulting pH was previously adjusted to 3.0-3.5 values range using stock solution in deionised water of HNO₃ (0.1 M), before biomass addition. The pH adjustment introduced increases lower than 1% in the final assay volume.

Batch and continuous trials were carried out using 0.5 and 25 dm³ solutions of appropriate metal concentration, respectively by dilution of the stock solution. Required quantities of cork granulates were also added.

Samples were collected at regular times and clarified by centrifugation (MLW (Germany) model TH12 centrifuge). The supernatants were analysed for metal concentration, by AAS. pH of the initial metal solutions was adjusted to 3 in all experiments and the final solutions pH was also measured.

Tubular Reactor in batch and continuous experiments

Diagrams of the tubular reactors used in both batch and continuous lead bioremoval experiments are shown in Figures 1 and 2, respectively. The main body was a glass column with an internal diameter of 5 cm and a height of 21.3 cm. The liquid volume inside the bed was in the range of 37-138 cm³, according to the different cork granulates quantity used (5-20 g, respectively). In the batch trials, a liquid volume of 500 cm³ (working liquid volume) was permanently recirculated between the packed column and the auxiliary vessel, at a flow rate of 480 cm³.dm⁻³, using a Watson-Marlow (USA) model 505-S peristaltic pump.

Pre-treatment with solvents

Cork biomass was pre-treated with three solvents – deionised water, ethanol and ethyl acetate – for extraction of phenols and tannins (deionised water and ethanol) and waxes and fats (ethanol and ethyl acetate). The pre-treatments were performed by contacting 8.5 g of cork granulates (1-2 mm) with 750 cm³ of each solvent during 6 hours in a Soxhlet extractor. Afterwards, the mixture was filtered and the solid was oven dried at 40 °C.

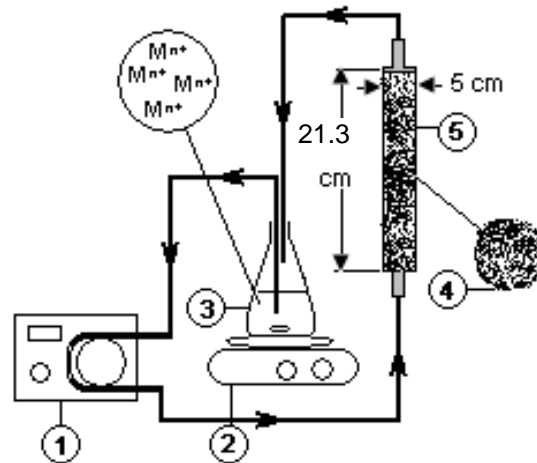

Figure 1: Diagram of the tubular reactor in batch experiments and its associated equipment. (1)-Recirculation pump; 2- Magnetic stirring; 3- Auxiliary vessel; 4-Biosorbent; 5-Biosorption column.

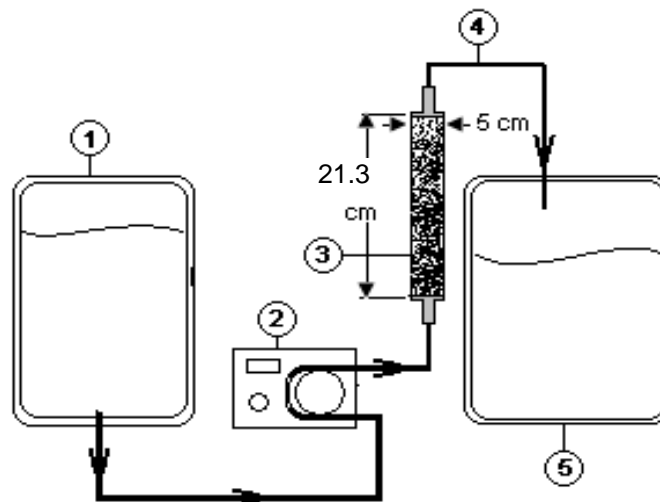

Figure 2: Diagram of the tubular reactor in continuous experiments and its associated equipment. (1)-Fed vessel; 2- Peristaltic pump; 3- Biosorption column; 4-Output (effluent); 5-Reception tank.

Initial pH effect

The effect of the initial solution pH on the metal removal was tested by adjusting the initial pH of 10 mg dm^{-3} Pb(II) aqueous solutions to values between 2.0 and 8.0. Stock solutions in deionised water of NaOH (0.1 M) and HNO₃ (0.1 M), were used for pH adjustment. The pH adjustments introduced changes in the final assay volumes of always under 1 %.

Initial metal concentrations remaining in solution were measured after pH adjustment and before biomass addition. The biosorbent was then added and residual metal concentrations in the

solution were followed during 6 hours, without further pH adjustment. Parallel sets of flasks were followed, without added biomass.

RESULTS AND DISCUSSION

The following data correspond to an average of four independent experiments, with standard deviations lower than 10%.

Batch with total external recirculation experiments

Influence of the pre-treatment with solvents

The aim of cork residues pre-treatment with different solvents was to achieve an increase of the number of groups responsible for heavy metal removal by extraction of phenol, tannin, wax and fat molecules.

Table 1 presents the influence of pre-treatments on the removal of lead by with cork granulates.

Table 1: Pb(II) removal yields using as biosorbent original cork residues (without pre-treatment) and pre-treated with different solvents.

Cork residues	Without treatment	Treated with deionised water	Treated with Ethanol	Treated with ethyl acetate
Bioremoval yield (%)	93	80	88	83

The results listed in Table 1 showed that the performance of the cork residues was not improved by any of the tested treatments. In fact, cork biomass without treatment provided a higher removal yield (93%) than biomass submitted to those extraction experiments. Therefore, the expected improvement was not verified and the use of original cork granulated, without treatments, will be the best option.

Effect of the initial metal solution pH

Taking into account the previously mentioned importance of the pH (Marques *et al.*, 2000; Marques, 2002) on metal ion bioremoval, tests were undertaken with different initial pH values of unbuffered Pb(II) solutions in water. In these tests, initial pH values of 10 mgdm⁻³ aqueous metal solutions were adjusted in the range of 2.0-8.0, before addition of the biosorbent.

Figure 3 shows the effect of the initial solution pH on the residual dissolved ion concentration, measured immediately after pH adjustment, and after 6 hours of incubation (equilibrium attained), in the absence and in the presence of biomass.

Without biosorbent, it was verified that an initial solution pH increase led to an immediate ion concentration decrease, for all metals, due to precipitation phenomena (Figure 3). The evolution of pH was also registered along the process and no significant pH changes were observed in the presence and absence of cork residues. Furthermore, in biomass-free experiments it was verified that both pH and metal concentration remained constant during the 6 hours of incubation, showing that the presence of cork granulates was required for the metal removal levels presented in Figure 3.

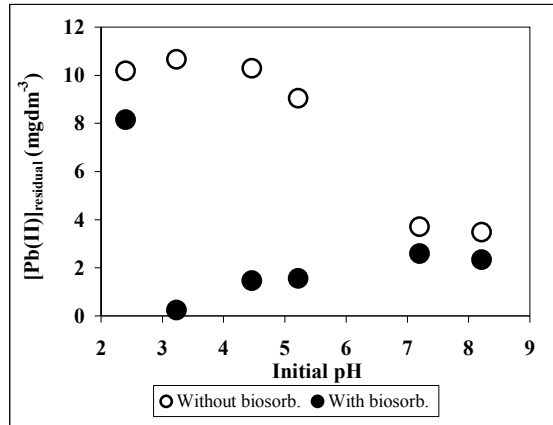

Figure 3: Initial pH effect on the residual Pb(II) concentration in the presence and absence of cork residues.

As can be seen from Figure 3, in the presence of biomass the initial pH that led to the lowest residual Pb(II) ions concentration was in the 3.0-3.5 range (removal yield of 98%). Therefore, this initial pH range was considered the most interesting for further experiments.

Uptake capacity of cork residues

Adsorption isotherms, which are the presentation of the amount of solute adsorbed per unit of adsorbent, as a function of equilibrium concentration in bulk solution at constant temperature, were studied. The equilibrium data obtained were fitted to Langmuir and Freundlich isotherms. The initial Pb(II) concentrations were between 10 and 360 mgdm⁻³. Biosorbent concentration and solution recirculation flowrate were 20 gdm⁻³ and 750 cm³h⁻¹, respectively, as previously established (Dora, 2004; Marques *et al.* 2005). Figure 4 show that the metal adsorption on the cork followed Langmuir model (correlation with experimental results, $r^2 = 0.995$). Other authors observed the same behaviour for Cr(III) removal by cork powder (Machado *et al.*, 2002) and Zn(II) and Ni(II) (Chubar *et al.*, 2004).

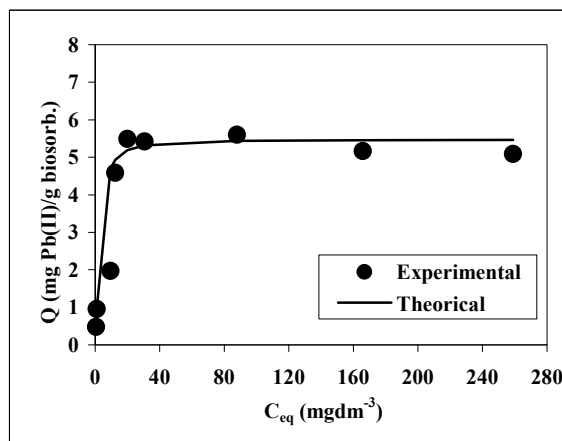

Figure 4: Equilibrium isotherm of Pb(II) bioremoval by cork residues.

Fitting of the experimental data to the linear form of the Langmuir isotherm described by equation (3) led to the determination of maximum Pb(II) uptake capacity ($Q_{max.}$) of cork biomass as $5.3 \text{ mgPb(II)g}^{-1}\text{cork}$ (Figure 5).

$$\frac{C_{eq}}{Q} = \frac{1}{Q_{max} \times a_L} + \frac{C_{eq}}{Q_{max}} \quad (3)$$

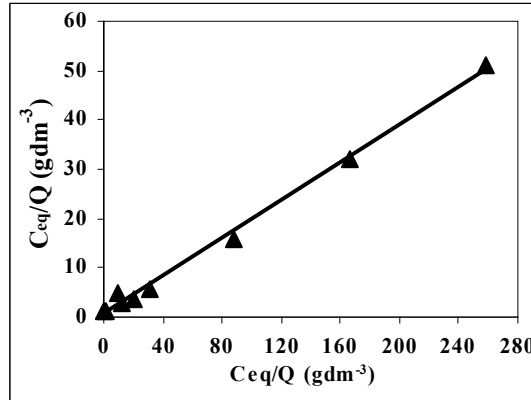

Figure 5: Linear plot of the Langmuir isotherm

Optimisation of continuous bioremoval of Pb(II) from aqueous solutions

Taking into account the metal uptake yield and the volume of effluent containing a Pb(II) concentration $\leq 1 \text{ mgdm}^{-3}$ (MAV), biosorbent quantity and input flowrate values were optimised using factorial design methodology. The response surfaces to estimate both efficiencies over independent variables biosorbent concentration and input flowrate were depicted in Figures 6 and 7.

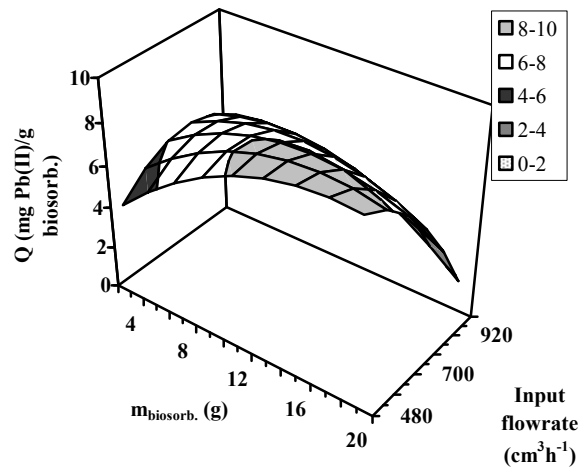

Figure 6: Response surface plot for the effects of biomass concentration and input flowrate on the Pb(II) removal. $[\text{Pb(II)}]_i = 10 \text{ mgdm}^{-3}$; Fed volume = 25 dm^3 ; $\text{pH}_i = 3-3.5$.

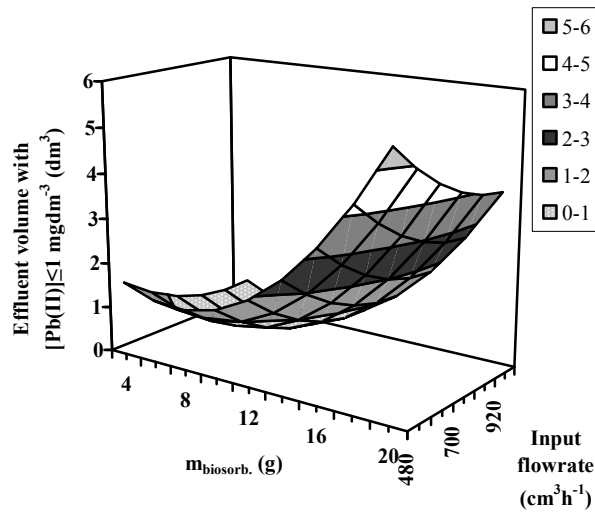

Figure 7: Response surface plot for the effects of biomass concentration and input flowrate on the effluent volume with $[Pb(II)] \leq 1 \text{ mgdm}^{-3}$. $[Pb(II)]_i = 10 \text{ mgdm}^{-3}$; Fed volume = 25 dm^3 ; $pH_i = 3-3.5$.

The parameters values giving the maximum removal efficiency of Pb(II) were found to be biosorbent quantity = 20 g and input flowrate = $590 \text{ cm}^3\text{h}^{-1}$. Increase of the cork concentration resulted in an increase of both the metal uptake yield and the volume of effluent containing a Pb(II) concentration $\leq 1 \text{ mgdm}^{-3}$ while the input flowrate increase led to the decrease process efficiency. These behaviours can be associated to an increase of the contact surface and time in referred conditions.

In the previous established optimal conditions, two tubular reactors were studied running in sequential mode. Figure 8 shows clearly that a larger number of tubular reactors connected in series led to an increase of the effluent volume containing a Pb(II) concentration $\leq 1 \text{ mgdm}^{-3}$ in both second reactor output and reception tank (from 5 to 10 dm^3).

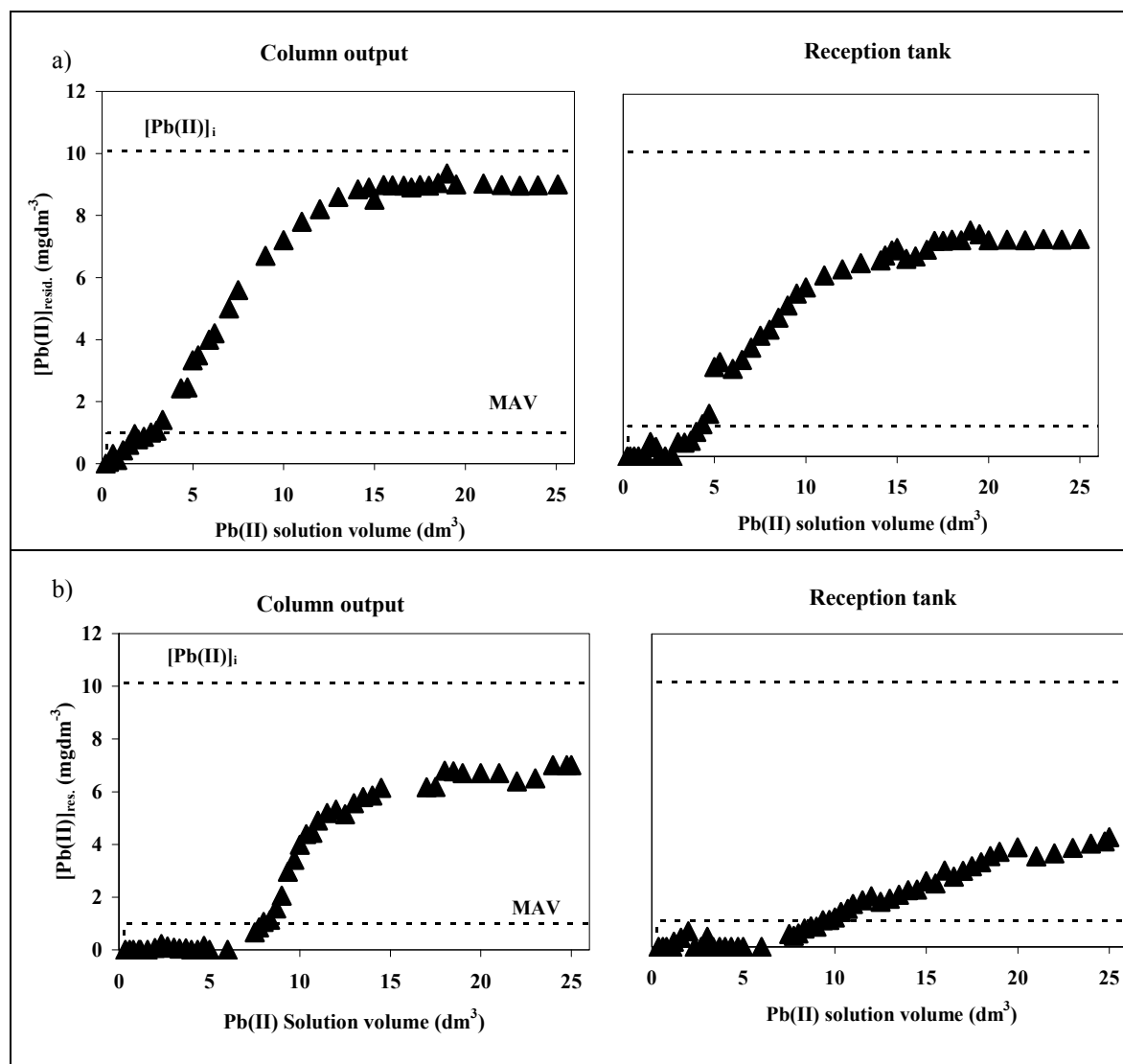

Figure 8: Breakthrough curve of Pb(II) concentration in the column output and final reception tank, using one (a) and two (b) tubular reactors in sequence mode for continuous removal by cork granulates.

Chemical characterization of the effluent

Table 2 presents the results obtained for the chemical characterization of the effluent before discharge, in terms of COD, TOC and phenols compounds. As can be verified all the values were lower than the ones allowed by environmental legislation, showing that in addition to this process being efficient for Pb(II) bioremoval from aqueous solutions, it also obtained an effluent that can be discharged in an aquatic medium.

Table 2: Chemical characterization, obtained after a heavy metal bioremoval process using cork residues as biosorbent, in terms of COD, TOC and phenols compounds.

Parâmetros	Values	Treated effluent	MAV
COD (mgdm⁻³)		83	150
TOC (mgdm⁻³)		23	(1)
Phenols compounds (mgdm⁻³)		<0,05	0,5

CONCLUSIONS

From the present study it can be concluded that waste cork granulates can be effectively used for Pb(II) bioremoval from dilute aqueous solutions in batch with recirculation continuous reactor arrangements. Though several studies using cork powder for heavy metals bioremoval have been referred in the literature, (Chubar *et al.*, 2004a; Chubar *et al.*, 2004b; Machado *et al.*, 2002; Santos *et al.*, 2004; Villaescusa *et al.*, 2002), a new system using Pb(II) removal in acidic effluents is presented in this work.

In the present system, higher Pb(II) bioremoval capacity values were attained using cork biomass without treatment as biosorbent (98%) when compared to the biomass submitted to previous extraction with deionised water (80%), ethyl acetate (83%) and ethanol (88 %). The Langmuir model showed a very good correlation with experimental results ($r^2=0.995$) and the Q_{max} was determined as being 5.3 mg Pb(II)/g cork.

The optimisation of continuous bioremoval of Pb(II) (10 mg/L) from 25 L of influent, regarding metal uptake yield and volume of effluent containing a Pb(II) concentration ≤ 1 mg/L (MAV), was carried out by the factorial design methodology, leading to the establishment of the best operating conditions (biosorbent quantity=20 g and input flowrate=590 cm³h⁻¹). In these conditions, two tubular reactors running in sequential mode were more efficient than one reactor alone, leading to the increase of the effluent volume with [Pb(II)] ≤ 1 mg/L in both reactor output and reception tank. Moreover, the chemical characterization of the treated effluent before discharge, in terms of COD, TOC and phenols compounds, showed that all values were lower than the ones allowed by Portuguese environmental legislation.

Finally, the finishing process studied in this work proved competitive comparatively to the conventional techniques due to their economic, ecological and technologic advantages.

AKCNOWLEDGMENTS

The authors thank Portuguese Cork Company Granotec for kindly providing us with cork granulates.

REFERENCES

- CHUBAR N, CARVALHO JR and CORREIA MJN (2004 a): Cork Biomass as Biosorbent for Cu(II), Zn(II) and Ni(II): *Colloids and Surfaces A* (230): 57-65.
- CHUBAR N, CARVALHO JR and CORREIA MJN (2004 b): Heavy metals biosorption on cork biomass: effect of the pre-treatment: *Colloids and Surfaces A* (238): 51-58.
- DORA M: Heavy metals bioremoval by cork, Graduation thesis, Faculdade de Ciências de Lisboa, 2004.
- GARG VK, GUPTA R, KUMAR R and GUPTA RK (2004): Adsorption of chromium from aqueous solution on treated sawdust: *Biores. Technol* (92): 79-81.
- Gil L and Moiteiro C: Cork, in Ullmann's Encyclopedia of Chemical Technology, 2003.
- GIL L: A Cortiça e o vinho, Ed. CEDINTEC/INETI, Lisbon, 2006.
- GIL L: Cortiça: Produção, Tecnologia e Aplicação, INETI, Lisbon, 1998.
- GÖKSUNGUR Y, ÜREN S and GÜVENÇ U (2005): Biosorption of cadmium and lead ions by ethanol treated waste baker's yeast biomass: *Biores. Technol* (96): 103-109.
- MACHADO R, CARVALHO JR and CORREIA MJN (2002): Removal of trivalent chromium (III) from solution by biosorption in cork powder: *J Chem Technol Biotechnol* (77): 1340-1348.
- MARQUES PASS, MOTA D, PEREIRA C, GIL L and ROSA MF (2005): Continuous heavy metals removal from aqueous solutions by cork granulates: National Patent N° 103286.
- MARQUES PASS, PINHEIRO HM and ROSA MF (2000): pH effects on the removal of Cu²⁺, Cd²⁺ and Pb²⁺ from aqueous solution by waste brewery biomass: *Bioproc. Eng.* (23): 135-141.
- MARQUES PASS, PINHEIRO HM and ROSA MF (2006): Cd(II) removal from aqueous solution by immobilised waste brewery yeast in fixed-bed and airlift reactors: submitted to *Desalination*.
- MARQUES PASS: Decontamination of heavy metal aqueous solutions by microbial biomass. PhD thesis, Instituto Superior Técnico, Lisbon, 2002.
- PALMA G, FREER J and BAEZA J (2003): Removal of metal ions by modified *Pinus radiata* bark and tannins from water solutions: *Wat Res* (37): 4974-4980.
- SANTOS S, Machado R, Correia MJN and Carvalho JR (2004): Treatment of acid mining waters: *Minerals* (17): 225-232.
- SARIN V and PANT KK (2006): Removal of chromium from industrial waste by using eucalyptus bark: *Biores. Technol* (97): 15-20.
- SINGH KK, TALAT M and HANSAN SH (2006): Removal of lead from aqueous solutions by agricultural waste maize bran: *Biores. Technol* (97): 2124-2130.
- VILLAESCUSA I, Fiol N, Cristiani F, Floris C, Lai S and Nurchi VM (2002): Copper(II) and nickel(II) uptake from aqueous solutions by cork wastes: a NMR and potentiometric study: *Polyhedron* (21): 1363-1367.