

Conference on Electronics, Telecommunications and Computers – CETC 2013

PV System with Maximum Power Point Tracking: Modeling, Simulation and Experimental Results

R.J. Pereira^{a,d}, R. Melício^{a,b,*}, V.M.F. Mendes^{a,c}, A. Joyce^{a,d}

^aUniversidade de Évora, Department of Physics, 7004-516 Évora, Portugal

^bIDMEC/LAETA, Instituto Superior Técnico, Universidade de Lisboa, 1049-001 Lisbon, Portugal

^cInstituto Superior de Engenharia de Lisboa, Department of Electrical Engineering and Automation, 1959-007 Lisbon, Portugal

^dNational Laboratory of Energy and Geology (LNEG), 1649-038 Lisbon, Portugal

Abstract

This paper focuses on the photovoltaic cell five parameters modeling, consisting on a current controlled generator, single-diode, a shunt and series resistances. An identification of the parameters for a photovoltaic system supported the maximum power point tracking implementation based on $\partial P/\partial V$. The identification of parameters and the performance obtained with the equivalent circuit model for a solar module are validated by data measured on an in situ photovoltaic system.

© 2014 The Authors. Published by Elsevier Ltd. This is an open access article under the CC BY-NC-ND license (<http://creativecommons.org/licenses/by-nc-nd/3.0/>).

Peer-review under responsibility of ISEL – Instituto Superior de Engenharia de Lisboa, Lisbon, PORTUGAL.

Keywords: PV panel; MPPT; modeling; simulation; experimental results

1. Introduction

Energy demand intensification, the announced fossil fuels shortage and the call for reduction on carbon footprint are in 21st century an issue persisting on the international agenda. Global awareness on the importance of energy savings and of energy efficiency [1] have been and will be as a point in case in order to achieve sustainability. Also, wind and solar energy sources are becoming more attractive to go into exploitation due not only to the average increase on fossil fuels prices and the call for reduction on carbon footprint, but also to the technologic development allowing for the exploitation on large scale and on Disperse Generation (DG) owned by consumers.

* Corresponding author. Tel.: +351-266-745-372; fax: +351-266-745-394.
E-mail address: ruimelicio@uevora.pt

A photovoltaic (PV) system directly converts solar energy into electric energy. The main device of a PV panel is a solar cell. Cells may be grouped to form arrays and panels. A PV array may be either a panel or a set of panels connected in series or parallel to form large PV systems without or with tracking systems in order to achieve higher values of energy conversion during sunny days due to the diverse perpendicular positions to collect the sun's irradiation. Power electronic converters have been developed for integrating renewable energy sources with the electric grid. The use of power electronic converters, namely inverters, allows for operation of the PV system and enhanced power extraction. The inverter is needed for two reasons in a PV system. First, to adjust the low DC voltage generated by the PV module to the voltage level in the electric grid. Second, the power delivered from the modules is very sensitive to the point of operation, and the inverter should therefore incorporate functionality for Tracking the Maximum Power Point (MPP) [3]. The MPP tracking algorithm based on $\partial P/\partial V$ feedback is in use on PV systems to adjust the state on and off of the power converters IGBT's to achieve the MPP [4] conversion of solar energy into electric one.

This paper is organized as follows. Section 2 presents the five parameters modeling for a PV system with MPPT. Section 3 presents a case study. Finally, concluding remarks are given in Section 4.

Nomenclature

G	solar irradiance
T	cell <i>p-n junction</i> temperature
R_p	equivalent shunt resistance
R_s	equivalent series resistance
I	output current
V	output voltage
I_s	photo generated electric current
I_{d1}	current at diode D_1
I_p	leakage current
V_T	thermal voltage of a solar cell
k	Boltzman's constant
q	electron charge
I_0	diode reverse bias saturation current
m	diode ideality factor
ΔI	current increment
ΔV	voltage increment

2. Modeling

2.1. Solar module

The PV cell five parameters modeling [5] is given by:

$$I = I_S - I_0 \left(e^{\frac{V + I R_S}{m V_T}} - 1 \right) - \frac{V + I R_S}{R_p} \quad (1)$$

$$\text{where } V_T = kT/q \quad (2)$$

This cell is represented by an equivalent circuit consists on a current controlled generator, a single-diode, a shunt

and series resistances and is also suitable for a set of identical cells connected in series or parallel, if all cells are submitted to the same solar irradiation. The electric equivalent circuit is shown in Fig. 1.

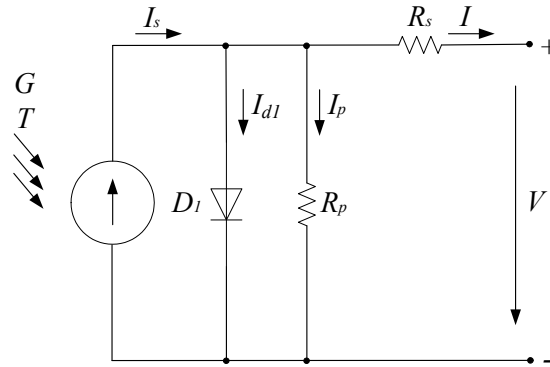

Fig. 1. PV equivalent circuit.

The model in (1) is given by an implicit function that has to be solved by an iterative method to determine for instance the output current in function of the output voltage. From (1), considering the short-circuit condition, the photo generated electric current is given by:

$$I_S = \frac{I_{SC}(R_s + R_p)}{R_p} + I_0(e^{\frac{I_{sc}R_s}{mV_T}} - 1) \tag{3}$$

The second term of (3) can be disregarded in comparison with the first term. Hence, the photo generated electric current can be approximated by the expression given by:

$$I_S = \frac{I_{SC}(R_s + R_p)}{R_p} \tag{4}$$

At condition of MPP, are valid the equalities given by:

$$\left(\frac{\partial P}{\partial V}\right)_{MPP} = \left[\frac{\partial}{\partial V}(VI)\right]_{MPP} = I_{MPP} + V_{MPP}\left(\frac{\partial I}{\partial V}\right)_{MPP} = 0 \tag{5}$$

From (1) the incremental conductance (INC) at MPP is given by:

$$\left(\frac{\partial I}{\partial V}\right)_{MPP} = -\frac{V_{MPP} - I_{MPP}R_s}{V_{MPP}} \left(\frac{I_0 e^{\frac{V_{MPP} + I_{MPP}R_s}{mV_T}}}{mV_T} - \frac{1}{R_p}\right) \tag{6}$$

From (5) and (6), the current at MPP [6] is given by:

$$I_{MPP} = (V_{MPP} - I_{MPP}R_s) \left(\frac{I_0 e^{\frac{V_{MPP} + I_{MPP}R_s}{mV_T}}}{mV_T} - \frac{1}{R_p}\right) \tag{7}$$

2.2. MPPT algorithm

The input parameters are values of the voltage and current of the PV module. The MPPT algorithm addressed is based on the INC method to assess the sign of (6) [7] and then make the convenient adjustment for tracking MPP. The MPPT algorithm considering is shown in Fig. 2.

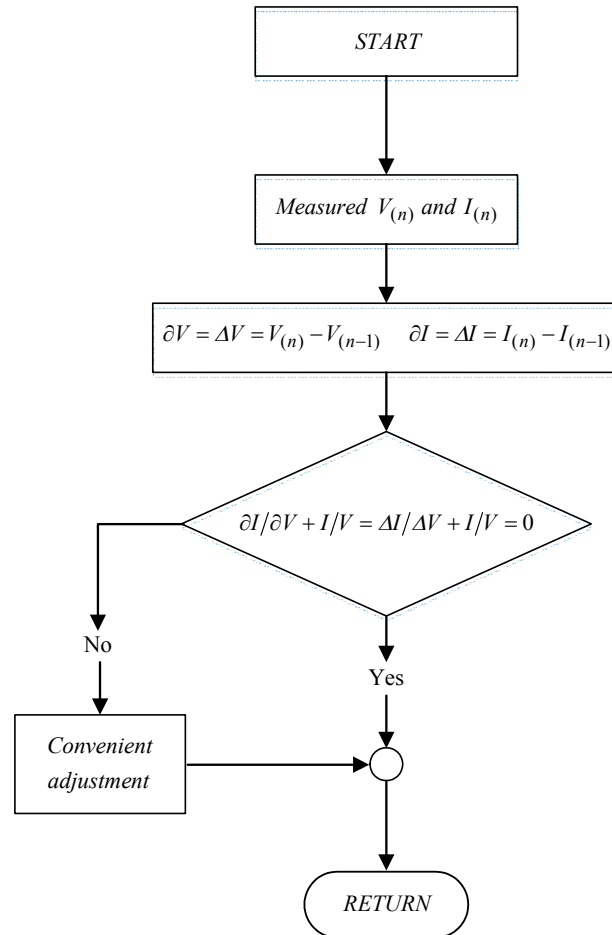

Fig. 2. MPPT algorithm

In the above algorithm, if it is found that $\partial P/\partial V = 0$ is met, then the algorithm has found the MPP point. But usually the algorithm iterates around $\partial P/\partial V = 0$ until it is eventually found $\partial P/\partial V = 0$, i.e., if $\partial P/\partial V > 0$, an incremental adjustment is set in order to increase the out voltage to be able of founding the MPP with this adjustment; if $\partial P/\partial V < 0$, an adjustment is set in order to decrease the out voltage to be able of founding the MPP; and so on.

3. Case study

The model for the solar cell with single-diode, shunt and series resistances is implemented in Matlab/Simulink® with Simscape library. The simulation results were compared with experimental observation carried out for a monocrystalline PV module technology obtained at a sunny day. The data measured from the PV modules is taken from a photovoltaic facility at the Laboratório Nacional de Energia e Geologia (LNEG) in Lisbon, Portugal. The

coordinates for the PV modules site are: 38°46'18.50"N, 9°10'38.50"W. The data for the first generation of silicon monocrystalline solar modules Eurener MEPV 230 at STC [8] are shown in Table 1.

Table 1. Data for the Eurener MEPV 230 solar module at STC

Technology	Short-circuit current	Open circuit voltage]	Current at MPP	Voltage at MPP
Monocrystalline	8.88 A	36.12 V	8.13 A	28.45 V

The photovoltaic facility at the LNEG with silicon monocrystalline solar modules MEPV 230 is shown in Fig. 3.



Fig. 3. Photovoltaic facility at the LNEG.

The Simulink structure for the PV system with MPPT in is shown in Fig. 4.

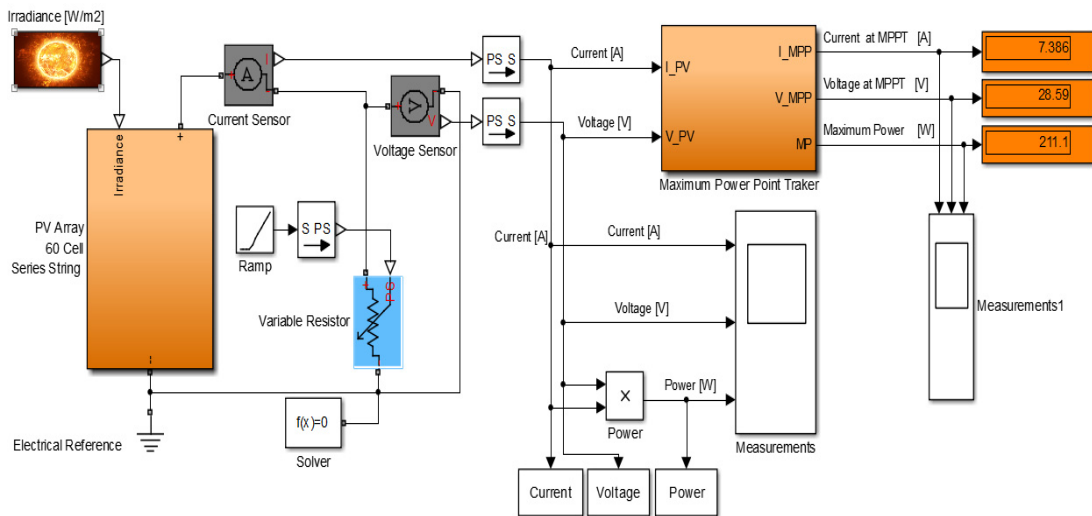

Fig. 4. PV system with MPPT structure.

For the tested PV modules, the characteristic curve is measured outdoors, quasi-simultaneously with the measurement of the reference unit I-V curve. The I-V curve is then converted to STC conditions by using the procedure described in IEC 60891. The simulation results are compared with experimental observation carried out for a monocrystalline PV module technology. The I-V and P-V curves with MPP simulated and experimental at STC conditions are shown in Fig. 5.

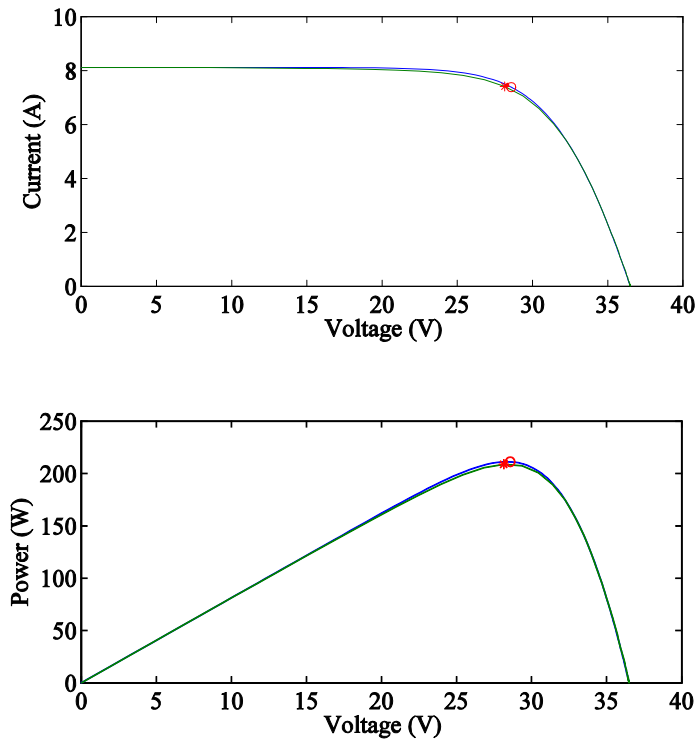

Fig. 5. The I-V and P-V curves with MPP simulated and experimental at STC conditions.

A comparison between simulated and the experimental results shows a satisfactory achievement in this modeling for the PV system at experimental testing. Also, the observation of the MPPT tracking algorithm is favorable and with solar irradiance varying not to quickly assessment of a satisfactory neighborhood of the MPP point is possible after an acceptable number of iterations or is possible to follow the MPP when not to steady irradiance is submitted to the system.

4. Conclusion

The solar cell model of five parameters, consisting of one current controlled generator, one single-diode, one shunt and series resistances is used in this paper in order to achieve an acceptable approximation for the performance of a testing monocrystalline PV modules technology.

The five parameters can be used to simulate the performance of the PV system before installation in situ in what regard MPP and the performance given by the I-V and P-V curves. The simulation results are fundamental to assess the designer in what regards extracting the maximum energy and protection of the system.

The five parameters identified for the monocrystalline PV modules technology allowed the data for tracking the MPP and a comparison of the simulation results with the experimental observation has assessed the favorable ability of the INC method to track the MPP under acceptable irradiance and temperature changes.

Acknowledgements

This work was partially supported by National Energy and Geology Laboratory (LNEG) in Lisbon, Portugal, and by QREN (Portuguese National Strategic Reference Framework) project “SOL3”. This work was partially supported by Fundação para a Ciência e a Tecnologia, through IDMEC under LAETA, Instituto Superior Técnico, Universidade de Lisboa, Portugal.

References

- [1] Seixas M, Melício R, Mendes VMF. A simulation for acceptance of two-level converters in wind energy systems. In: Proc. 3.^{as} Jornadas de Informática da Universidade de Évora - JIUE2013. Évora, Portugal; 2013. p. 75-9.
- [2] Blaabjerg F, Chen Z, Kjaer SB. Power electronics as efficient interface in dispersed power generation systems. *IEEE Transactions Power Electronics* 2004;19:1184-9.
- [3] Yang Y, Zhao FP. Adaptive perturb and observe MPPT technique for grid- connected photovoltaic inverters. *Procedia Engineering* 2011;23:468-73.
- [4] Roncero-Clemente C, Stepenko S, Husev O, Miñambres-Marcos V, Romero-Cadaval E, Vinnikov D. Three-level neutral-point-clamped quasi-Z-source inverter with maximum power point tracking for photovoltaic systems. In: Camarinha-Matos LM, Tomic S, Graça P, editors. *Technological innovation for the internet of things*. Heidelberg: SPRINGER; 2013. p. 334-42.
- [5] Sahoo NC, Elamvazuthi I, Nor NM, Sebastian P. PV panel modelling using Simscape. In: Proc. Int. Conf. Energy, Automation, and Signal - ICEAS2011. Bhubaneswar, India; 2011. p. 1-4.
- [6] Carrero C, Rodríguez J, Ramírez D, Platero C. Accurate and fast convergence method for parameter estimation of PV generators based on three main points of the I–V curve. *Renewable Energy* 2011;36:2972-77.
- [7] Bhatnagar P, Nema RK. Maximum power point tracking control techniques: state-of-the-art in photovoltaic applications. *Renewable Sustainable Energy Reviews* 2013;23:224-41.
- [8] Eurener Photovoltaic modules, http://www.eurener.com/fichastecnicas/Eurener_MEPV_en.pdf.